

**USER OPERATIONAL MANUAL**  
**CM20 DIGITAL CHRONOMETER**

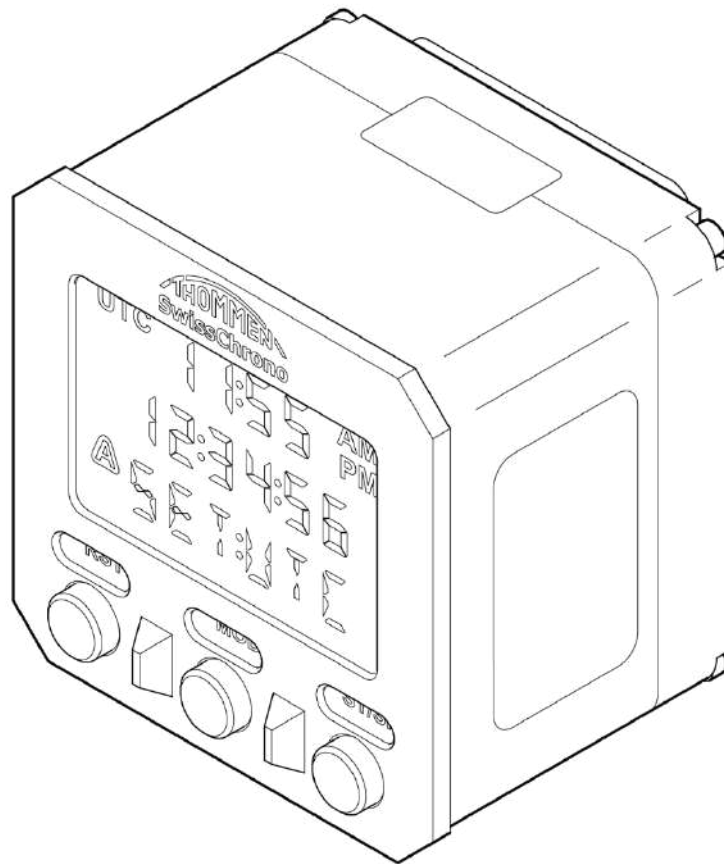



Revision: 1.5

29/04/2022

INTENTIONALLY BLANK

### RECORD OF REVISIONS

Rev.	Date	Reason for Revision	Prepared	Checked	Approved
1.0	NOV 4/2011	Initial Release	-	-	
1.1	JAN 9/2012	Format update	-	-	
1.2	JUN 12/2012	Content update	-	-	
1.3	AUG 20/2012	Layout corrections	-	-	Ulrich Dembinski
1.4	NOV 30/2018	Document updated in new format with TAE company address and logo. General grammatical corrections.	J. Garrett	M. Schaffner	M. Sreetharanathan
1.5	APR 29/2022	Removal of MID number (P/N 1613). General corrections and improvements.	 J. Garrett	 G. Schaffner	 A. Savin

INTENTIONALLY BLANK

### SERVICE BULLETIN LIST

SB No.	Subject	Rev.	Date

INTENTIONALLY BLANK

### LIST OF EFFECTIVE PAGES

SECTION	PAGE	REV.	DATE	SECTION	PAGE	REV.	DATE
Title Page	1	1.5	29/04/22	Introduction	1	1.5	29/04/22
	2	1.5	29/04/22		2	1.5	29/04/22
					3	1.5	29/04/22
					4	1.5	29/04/22
Record of Revisions	1	1.5	29/04/22				
	2	1.5	29/04/22				
				Description and Operation	1	1.5	29/04/22
					2	1.5	29/04/22
					3	1.5	29/04/22
					4	1.5	29/04/22
Service Bulletin List	1	1.5	29/04/22		5	1.5	29/04/22
	2	1.5	29/04/22		6	1.5	29/04/22
					7	1.5	29/04/22
					8	1.5	29/04/22
List of Effective Pages	1	1.5	29/04/22		9	1.5	29/04/22
	2	1.5	29/04/22		10	1.5	29/04/22
					11	1.5	29/04/22
					12	1.5	29/04/22
					13	1.5	29/04/22
Table of Contents	1	1.5	29/04/22		14	1.5	29/04/22
	2	1.5	29/04/22		15	1.5	29/04/22
					16	1.5	29/04/22
					17	1.5	29/04/22
					18	1.5	29/04/22
				Fault Isolation	101	1.5	29/04/22
					102	1.5	29/04/22

INTENTIONALLY BLANK



### TABLE OF CONTENTS

RECORD OF REVISIONS	1
SERVICE BULLETIN LIST	1
LIST OF EFFECTIVE PAGES	1
TABLE OF CONTENTS	1
INTRODUCTION	1
1. Proprietary Notice	1
2. Purpose of this Manual	1
3. Manual Description	1
4. Revisions	1
5. Warnings, Cautions and Notes	2
5.1 Warnings	2
5.2 Cautions	2
5.3 Notes	2
6. Technical Support	2
7. Installer Responsibility	2
8. Document/Equipment Feedback	2
9. List of Abbreviations	4
DESCRIPTION AND OPERATION	1
1. Description	1
1.1 General	1
1.2 Function Description	1
1.3 Limitations	2
1.4 References	2
1.5 Warnings and Cautions	2
2. Operation	3
2.1 General	3
2.2 Pre-flight Procedures	3
2.3 Test Function	3
2.4 Display Options and Modes	3
2.4.1 Local Time (LT)	5
2.4.2 LT Set Page	6
2.4.3 Flight Time (FT)	7
2.4.4 Maintenance Timer in Hours (MTH)	8
2.4.5 Flight Timer Alarm (FTA)	9
2.4.6 Flight Timer Alarm (FTA) Set Page	10
2.4.7 Elapsed Timer (ET)	11
2.4.8 Elapsed Timer Down (ETD)	13
2.4.9 Elapsed Timer Down (ETD) Set Page	14
2.4.10 Alarms	15
2.5 User Programmable Modes	16
2.6 Operating Features	16
2.7 Other Programmable Modes	16

2.8	NVIS	16
2.9	Emergency Procedures	16
3.	Quick Reference Guide	17
FAULT ISOLATION		101
1.	General	101
1.1	Malfunctions	101
1.2	Troubleshooting	101

### INTRODUCTION

#### 1. Proprietary Notice

The information disclosed within this document, or separately supplied in furtherance of this document, includes the proprietary rights of Thommen Aircraft Equipment AG (TAE).

Neither this document nor the information disclosed herein or of a supplementary nature shall be reproduced or transferred to other documents or used or disclosed to others for manufacturing purposes, or for any other purposes, except as specifically authorized in writing by Thommen Aircraft Equipment AG (TAE). All rights are reserved.

#### 2. Purpose of this Manual

The information contained in this User Operational Manual is for operator reference use only.

For information concerning the installation and configuration of the CM20 Digital Chronometer, refer to the Installation and Operating Manual (CM20-INSOP), ATA 31-22-10.

For repair procedures, refer to the Component Maintenance Manual (CM20-CMM), ATA 31-22-10.

#### 3. Manual Description

The page blocks in this manual comply with the Air Transport Association of America (ATA) specification i2200.

#### 4. Revisions

Thommen Aircraft Equipment AG (TAE) gives the customers (that have a product guarantee) a complete revised manual when a change is included in a manual. The Record of Revisions section gives the reason for the changes done in the current revision.

A documentation revision service (with a customer portal) is also available for customers that have instruments/devices no longer covered by a product guarantee. This can be useful when an upgrade to the instrument/device can improve the operational life and/or reliability of older products.

The documentation revision service also includes the necessary Service Bulletins that upgrade/modify the device.

### 5. Warnings, Cautions and Notes

#### 5.1 Warnings



**WARNING: WARNINGS ARE GIVEN IN THE RELEVANT PAGE BLOCKS TO TELL PERSONNEL ABOUT SOMETHING THAT CAN CAUSE INJURY TO THEM. WARNINGS ARE GIVEN IMMEDIATELY BEFORE THE APPLICABLE TEXT TO WHICH THEY REFER.**

#### 5.2 Cautions



**CAUTION: CAUTIONS ARE GIVEN IN THE RELEVANT PAGE BLOCKS TO TELL PERSONNEL ABOUT SOMETHING THAT CAN CAUSE DAMAGE TO THE EQUIPMENT. CAUTIONS ARE GIVEN IMMEDIATELY BEFORE THE TEXT TO WHICH THEY REFER.**

#### 5.3 Notes

**NOTE:** Notes give helpful information to the personnel doing the task. Notes are included before or after the text to which they refer.

### 6. Technical Support

Approved Servicing Facilities exist worldwide. Please contact Thommen Aircraft Equipment AG at the address given below for information regarding the facility nearest to your location.

#### **THOMMEN AIRCRAFT EQUIPMENT AG**

Hofackerstrasse 48  
CH-4132 Muttens  
Switzerland

Phone: +41 (0)61 965 22 22

Email: [tech-support@thommen.aero](mailto:tech-support@thommen.aero)

Internet: [www.thommen.aero](http://www.thommen.aero)

### 7. Installer Responsibility

The installer (and/or Approved Service Facility) is responsible for the correct installation of the equipment. This includes the mechanical and electrical configuration and compatibility with the aircraft.

### 8. Document/Equipment Feedback

The Document / Equipment Defect Report (on the next page) gives the customer and/or Approved Service Facility a way to inform Thommen Aircraft Equipment AG about any defects regarding the equipment or discrepancies in the technical documentation. This feedback will help Thommen Aircraft Equipment AG to make continued improvements to the equipment and/or the technical documentation.

# User Operational Manual

## CM20 Digital Chronometer



DOCUMENT / EQUIPMENT DEFECT REPORT			
Aircraft Type	Serial No.	Manual No.	Operator

Date	Reported By	Contact Details

<b>Document / Equipment:</b>	
<b>Description of Defect:</b>	

<b>Corrective action taken to continue operation:</b>

Please send to:

**THOMMEN AIRCRAFT EQUIPMENT AG**

Hofackerstrasse 48

CH-4132 MuttENZ

Switzerland

Telephone: +41 (0)61 965 22 22

Email: tech-support@thommen.aero

### 9. List of Abbreviations

<b>Abbreviation</b>	<b>Description</b>
ATA	Air Transport Association
BAT	Battery
CM20	Digital Chronometer, Type CM20
CMM	Component Maintenance Manual
DEF	Defect
ERR	Error
ET	Elapsed Time
ETD	Elapsed Timer Down
FT	Flight Time
FTA	Flight Timer Alarm
INSOP	Installation and Operating Manual
LCD	Liquid Crystal Display
LED	Light Emitting Diode
LT	Local Time
MID	Master Identification Number
MOD	Mode
MTH	Maintenance Timer in Hours
NVIS	Night Vision Imaging System
REV	Revision
RST	Reset
RTCA	Radio Technical Commission for Aeronautics
SB	Service Bulletin
ST/SP	Start/Stop
TAE	Thommen Aircraft Equipment
UTC	Universal Coordinated Time

### DESCRIPTION AND OPERATION

#### 1. Description

##### 1.1 General

The CM20 is a digital chronometer with Universal Coordinated Time (UTC), Local Time (LT), Flight Timer (FT), Flight Timer Alarm (FTA), Elapsed Timer (ET), Elapsed Timer Down (ETD) and Maintenance Timer in Hours (MTH) functions.

It has the purpose to provide clock and timer capabilities in aviation cockpit applications.

##### 1.2 Function Description

The CM20 has a three-line negative image liquid crystal display (LCD). The top line shows the UTC; the middle and bottom lines show the selected additional function.

Dual mode (day/night) LED backlighting allows the display to be clearly read under all lighting conditions.

Located below the display, 3 push-buttons allow the user to easily switch between display modes or to start and stop the counter.

A built-in battery prevents the loss of stored time settings if there is a power interruption.

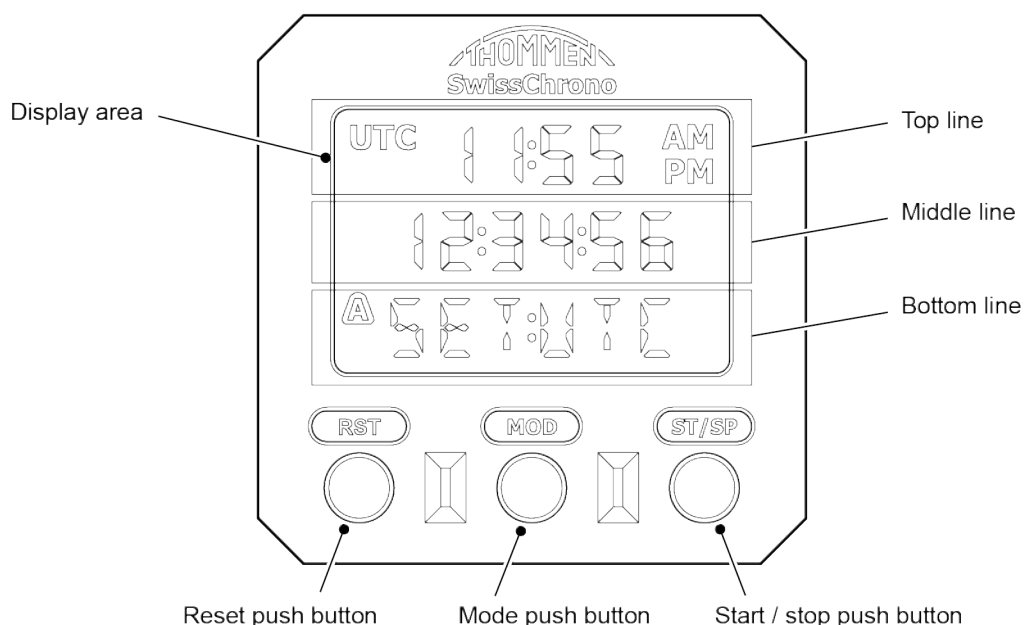

Figure 1 – CM20 Digital Chronometer, Front View

### 1.3 Limitations

The CM20 is vibration tested in accordance with category U2 of section 8.0 of RTCA/DO-160F, curves F and F1, without shock mounts.

The CM20 can therefore be installed in a helicopter or a fixed wing aircraft.

The CM20 can be operated within the following environmental limitations:

- Temperature: -45° C to +70° C (-49° F to +158°F)
- Altitude: Max. 55 000 ft (16 800 m)
- Humidity: 95% ±4% relative humidity

### 1.4 References

Refer to Installation and Operating Manual (CM20-INSOP) for installation and configuration instructions.

Refer to Component Maintenance Manual (CM20-CMM) for overhaul procedures.

### 1.5 Warnings and Cautions



**WARNING: IF AN AIRCRAFT PILOT IS USING NVIS GOGGLES, AN UNINTENDED SWITCH OF THE CM20 TO DAY MODE CAN INCREASE THE DISPLAY LUMINANCE TO A LEVEL WHERE THE PILOT CAN BE TEMPORARILY BLINDED. IN THIS CONDITION, THE NVIS GOGGLES CAN UNEXPECTEDLY SHUT DOWN.**



## 2. Operation

### 2.1 General

When electrical power is switched ON, the CM20 enters a self-test routine. During this time, all display segments are turned on for about five seconds, as shown below.



Figure 2 - Display Self-test

During normal mode of operation, the CM20 cycles between the different display pages by pressing the MODE button.

When available, the RESET button switches to the corresponding set display page. The value to be set starts blinking.

The top line always displays the UTC value; the content of the middle and bottom lines varies.

### 2.2 Pre-flight Procedures

If not already done, set Local Time (LT) to the desired value. Refer to LT Set Page (Description and Operation, section 2.4.2) for further details.

All timers (FT, ET, ETD) are automatically reset when power is supplied to the CM20.

### 2.3 Test Function

No manual function tests can be applied to the CM20. The power-up self-test detects all possible failures.

### 2.4 Display Options and Modes

Each function is represented by a display page.

The following figure shows all the display pages and the order in which they appear.

The following sub-sections (2.4.1 to 2.4.10) describe the display pages.

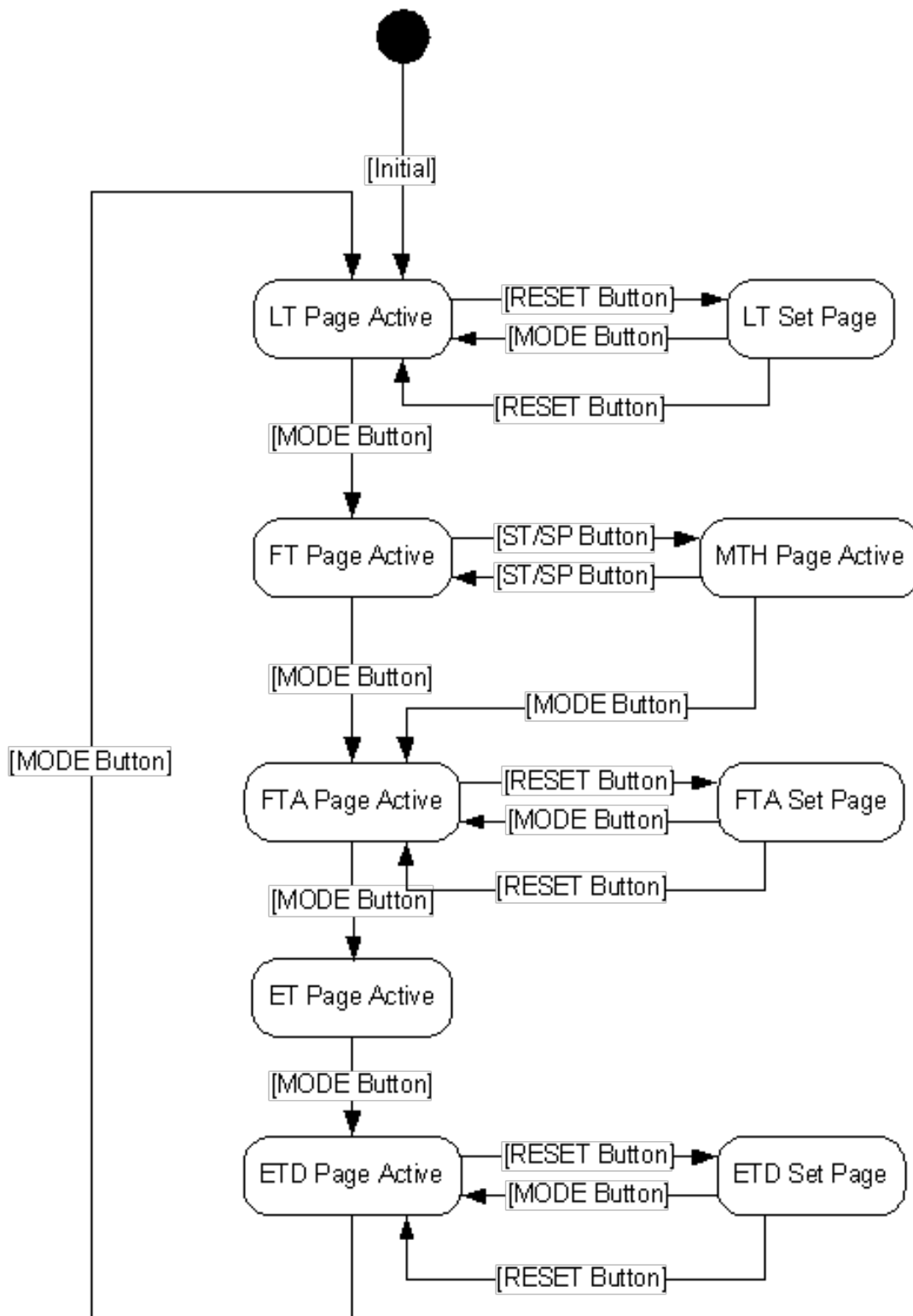

Figure 3 - Display Page Selection

### 2.4.1 Local Time (LT)

The first mode entered by CM20 is Local Time. The middle line displays the local time, the bottom line statically displays 'LT'.

Depending on the configuration setting, the local time can be displayed in 12-hour or 24-hour format. The local time varies from UTC by whole hours.



Figure 4 - LT in 12-hour Format



Figure 5 - LT in 24-hour Format

### 2.4.2 LT Set Page

The UTC and Local Time can be manually set. Use the RESET button to switch to the desired field to be set (e.g., UTC hours, LT hours, etc.) and increase the value with the START/STOP button.

Pressing the MODE button cancels the setting operation and leaves the time values unaltered.

The final RESET button push, after the seconds field, sets the time to the defined values.

A summary of the process is shown below.

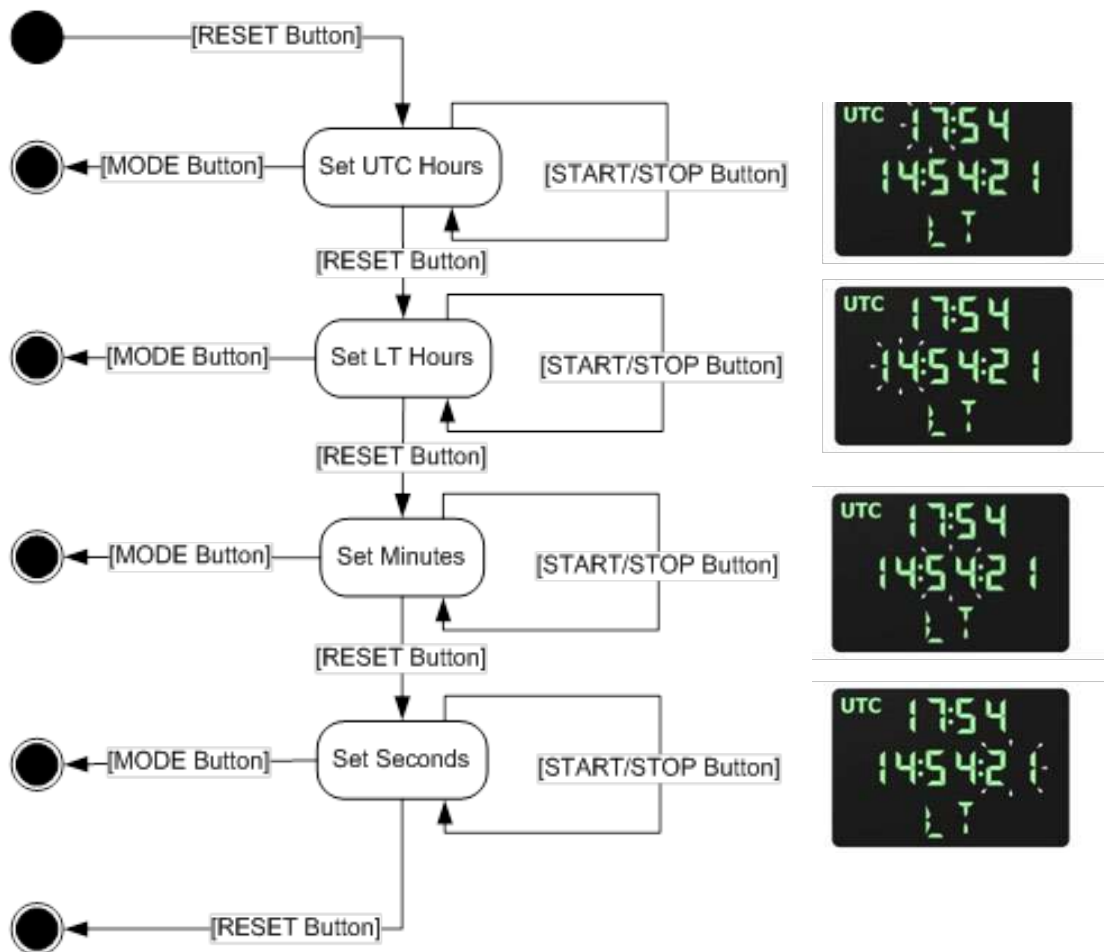

Figure 6 - Setting UTC and Local Time

### 2.4.3 Flight Time (FT)

Once airborne, the current flight time is automatically increased.

The middle line displays the time elapsed since flight beginning; the bottom line statically displays 'FT'.

The activation signal depends on the configuration setting.

The flight timer can reach a maximum value of 99:59:59 hours.



Figure 7 - Flight Timer

The START/STOP button switches between the FT page and the MTH page.

### 2.4.4 Maintenance Timer in Hours (MTH)

Similar to the FT page, this is information about accumulated flight hours. The counter is automatically increased upon activation of FLIGHT discrete and shows the total amount of flight time.

The top and middle lines are used to display the counter value. The bottom line statically displays 'MTH'.

Please note, the time is in decimal format with a maximum value of 999'999.99 hours. When the counter reaches this value, it stops increasing. The only possibility to reset the counter is via the RS-232 interface.



Figure 8 - Maintenance Timer in Hours

The START/STOP button switches back to Flight Timer display page. The MODE button switches to Flight Timer Alarm page.

### 2.4.5 Flight Timer Alarm (FTA)

A normal flight situation will require some actions to be performed depending on an elapsed flight time, for example dispatching messages, make turns, etc. The FTA is very helpful in this situation.

Simply set the FTA to the desired time before or during the flight. CM20 will launch an alarm when this time point is reached. The alarm can be in visible or audible form, depending on the aircraft configuration.

The middle line displays the FTA value, the bottom line statically displays 'FTA'.



Figure 9 - Flight Timer Alarm (Alarm Set)

The START/STOP button has no effect here. Using the RESET button, you enter the FTA Set Page.

### 2.4.6 Flight Timer Alarm (FTA) Set Page

Setting the FTA value is very similar to setting the Local Time. There are only two things which need to be considered when setting the FTA: the FTA value must be greater than zero (00:00:00) and greater than the Flight Timer, otherwise the alarm cannot be set.

After the alarm is set, the alarm annunciator is displayed on the left side of the bottom line ('A').

The maximum value for FTA is 99:59:59 hours.

Pressing the MODE button cancels the process.

The sequence of required steps are shown below.

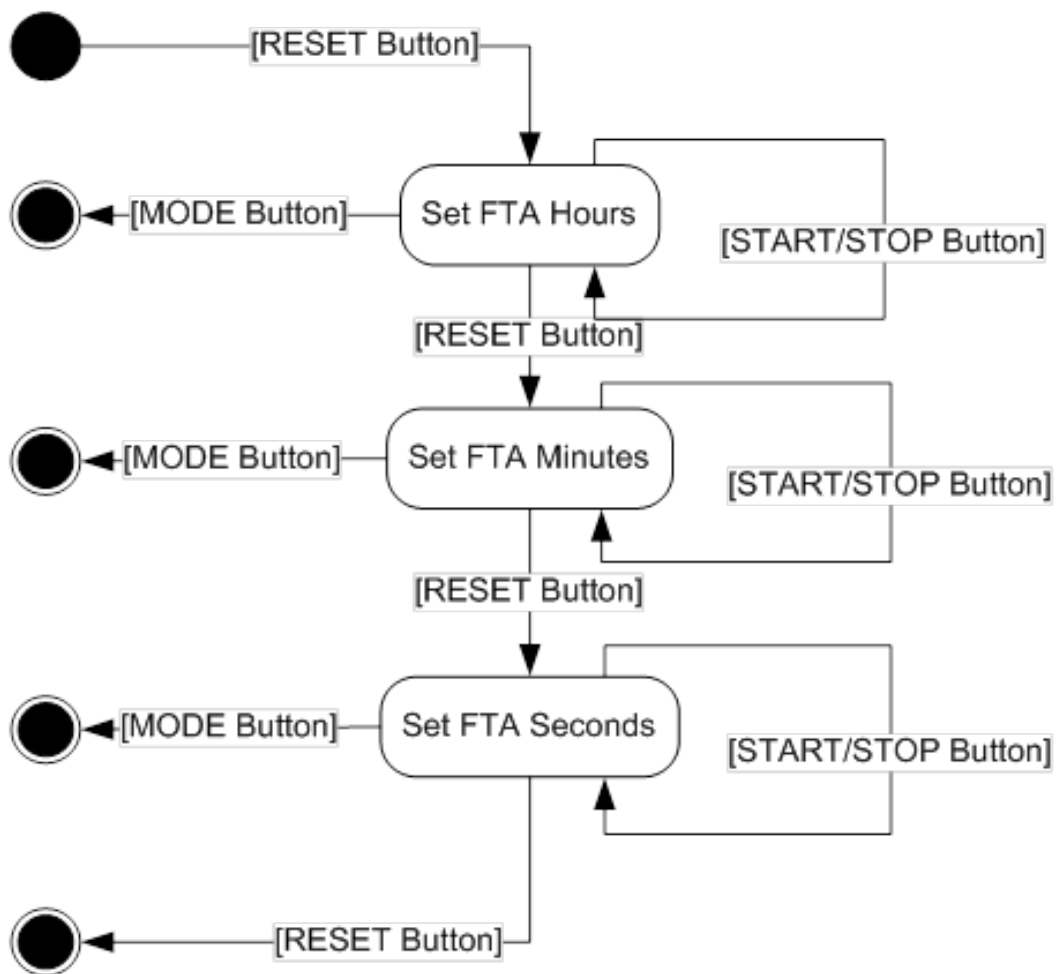

Figure 10 - Setting Flight Timer Alarm



### 2.4.7 Elapsed Timer (ET)

The Elapsed Timer is a chronometer with split times function. The maximum value that can be reached by ET is 99:59:59 hours. The middle line displays the ET value, the bottom line statically displays 'ET'.



Figure 11 - Elapsed Timer

An initial press on the START/STOP button starts the counter.

A second press on the START/STOP button freezes the displayed value, while CM20 continues to count in the background.

Another press on the same button updates the display.

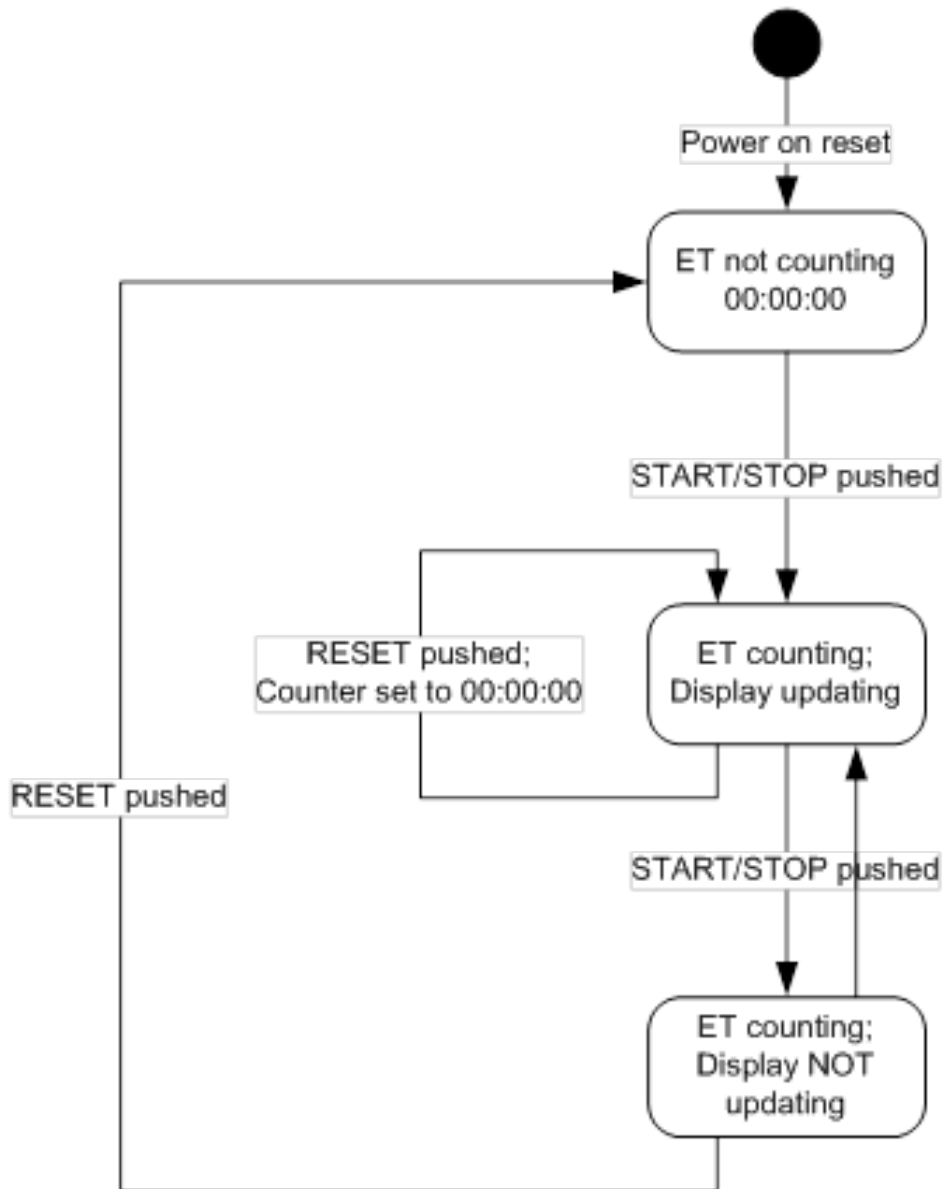

Figure 12 - Setting Elapsed Timer

Pressing the RESET button for approximately 2 seconds restarts the counter if not stopped previously, otherwise it simply resets it.

The figure above shows the functional behaviour.

The MODE button switches to the Elapsed Timer Down display page.

### 2.4.8 Elapsed Timer Down (ETD)

A second alarm can be launched after an arbitrary delay set by Elapsed Timer Down. This countdown alarm is independent of the flight time. It is manually triggered.

The timer allows a maximum value of 99:59:59 hours to count down. The middle line displays the current ETD value, the bottom line statically displays 'ETD'.

The countdown is initiated by pressing the START/STOP push button. It can be interrupted at any time by pressing the same button again.



Figure 13 - Elapsed Timer Down

When the value 00:00:00 is reached, the ETD Alarm is launched. The alarm can be in visible or audible form, depending on the aircraft configuration.

When the ETD Alarm is triggered, the countdown is reversed and will now start counting up the time since alarm activation.

Press the RESET button for approximately 2 seconds to reset the ETD value.

Short-press the RESET button to enter ETD Set Page. The MODE button restarts the display page cycle, starting with the Local Time display page.

### 2.4.9 Elapsed Timer Down (ETD) Set Page

Set the ETD in the same way as the FT Alarm. Use the RESET and START/STOP buttons to navigate to different units and to increase their values.

The maximum value that can be set is 99:59:59 hours.

The figure below shows the entire process.

Press the MODE button again to return to the LT page without modifying the ETD value.

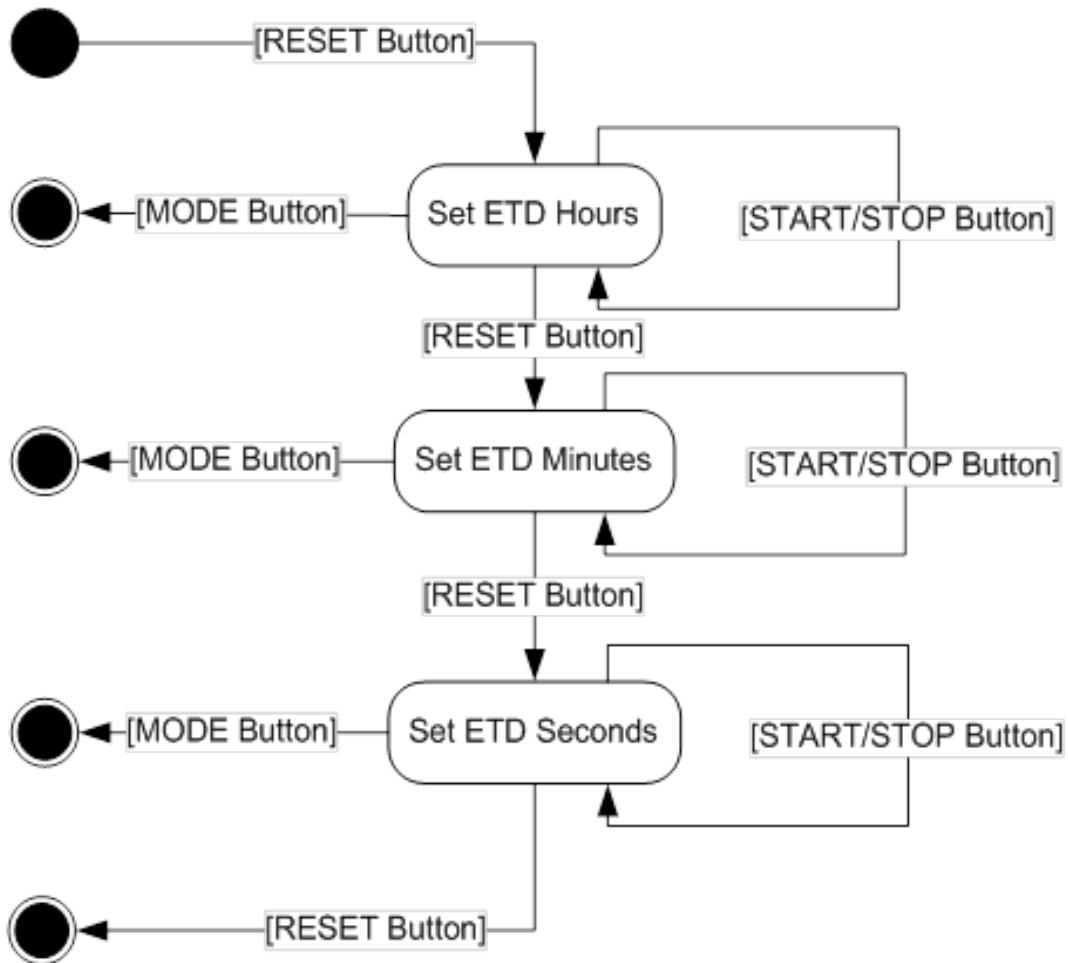

Figure 14 - Setting Elapsed Timer Down

### 2.4.10 Alarms

The CM20 can have two types of alarm: FTA and ETD. Each alarm is accompanied by an alarm annunciator and a visible or audible alarm output.

An alarm can have three states: Alarm NOT Set, Alarm Set and Alarm Activated.

Alarm NOT Set is the default state (no alarm is defined).

With Alarm Set (FTA or ETD), the alarm annunciator 'A' is displayed in the bottom line on the left side.



Figure 15 - Alarm Set (ETD)

When the alarm reaches its pre-set value, the alarm is activated. The bottom line blinks and if the CM20 is displaying the page of the active alarm, the middle line also blinks.



Figure 16 - Alarm Activated (ETD)

Pressing the START/STOP button stops the alarm.

### 2.5 User Programmable Modes

The CM20 does not feature any programmable modes.

### 2.6 Operating Features

The CM20 can be operated in two modes: Master or Slave, depending on configuration settings.

When two clocks are connected to each other, the Master CM20 sends continuously the UTC to the CM20 Slave clock.

Refer to Installation and Operating Manual (CM20-INSOP) for configuration settings.

### 2.7 Other Programmable Modes

Different display illumination behaviour can be applied to the CM20. The modification can be performed by an operator only.

In a default configuration, the Day Mode luminance is constant. When switching the cockpit panel to Night Mode, the luminance of CM20 display can be dimmed to adapt it to ambient instruments.

### 2.8 NVIS

The CM20, when operated in night mode, fulfils the conditions defined for NVIS, Type I, Class B.

### 2.9 Emergency Procedures

There are no emergency procedures to be followed for the CM20 in an emergency situation.

### 3. Quick Reference Guide



Figure 17 - CM20 Front View

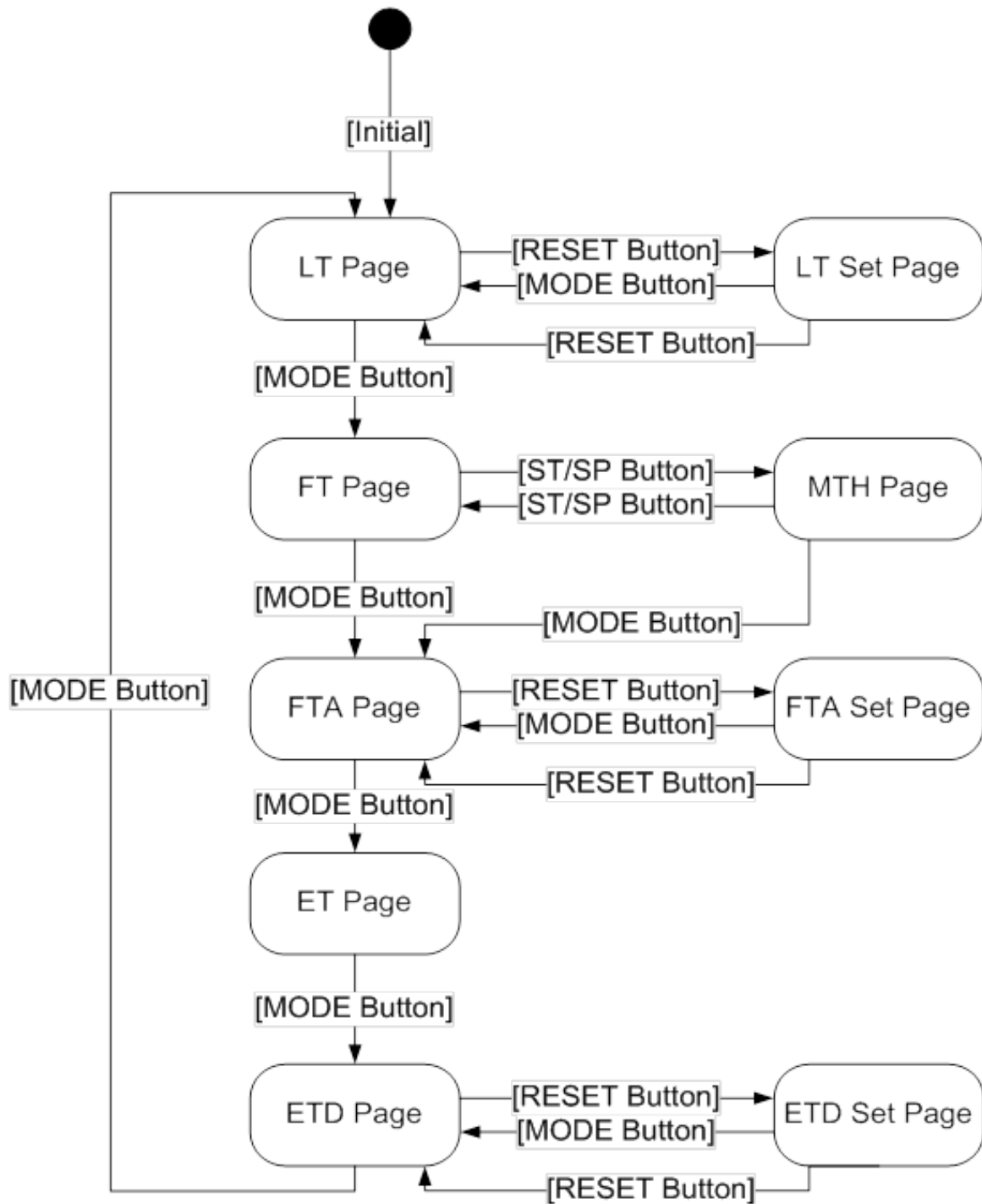

Figure 18 - Display Page Sequence



### FAULT ISOLATION

#### 1. General

This section gives the general fault isolation information to assist in locating and correcting any malfunctions with the CM20 Digital Chronometer.

##### 1.1 Malfunctions

A warning appears when the built-in battery doesn't provide enough power for safe operational mode.

The bottom line displays a warning message for five seconds. After that, the CM20 continues to operate normally.

The message can be:

Message	Description
BAT:LOW	Battery capacity is low, replace soon
BAT:DEF	Battery capacity is too low, replace immediately

Table 101 – Warning Messages

##### 1.2 Troubleshooting

If an unexpected error occurs during the operation of the CM20, the clock will be stopped.

The top and middle lines will statically display '--:--' and '--:--:--' respectively.

The bottom line will display 'ERR:<Code>'.

Make a note of the error code and inform the technical service about the error message.

Currently, the possible error codes displayed by the CM20 are:

Error Code	Description
001	Battery not detected

Table 102 - Error Codes

INTENTIONALLY BLANK